

4

3

2

1

D

D

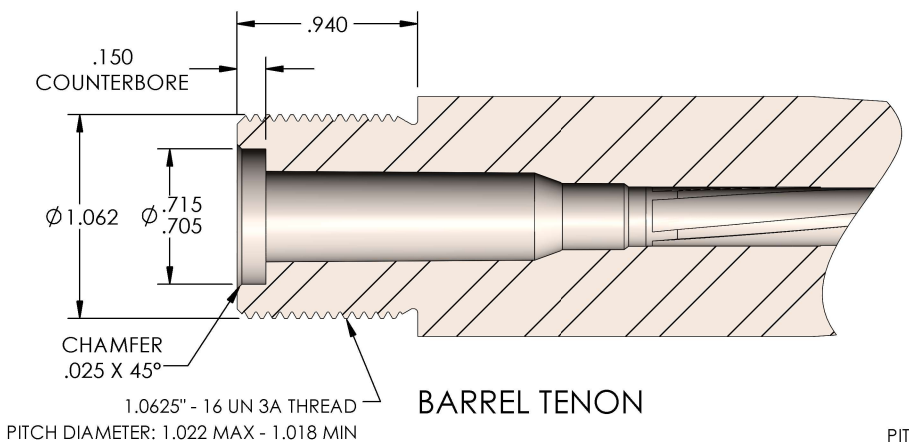

BARREL TENON

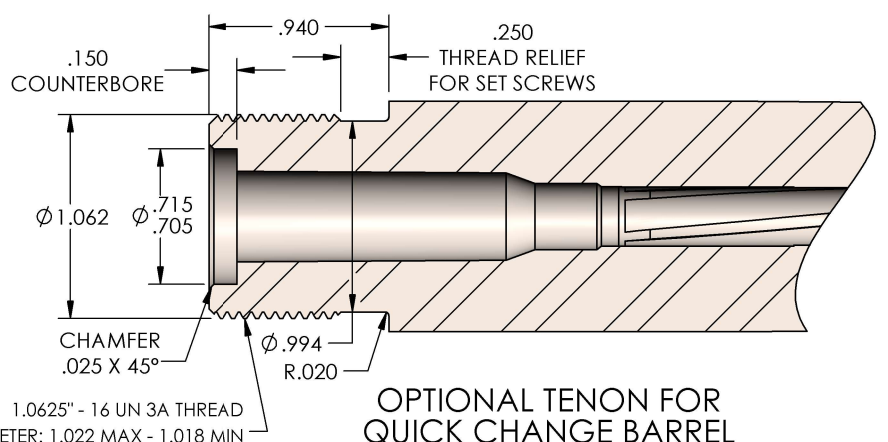

OPTIONAL TENON FOR QUICK CHANGE BARREL
(SET SCREWS ON RECEIVER)

CLEARANCES

- BOLT NOSE IS .010" FROM BOTTOM OF COUNTERBORE
- BOLT LUG FRONT IS .010" FROM END OF TENON
- BOLT NOSE TO COUNTERBORE RADIAL CLEARANCE IS .005" TO .010"

C

C

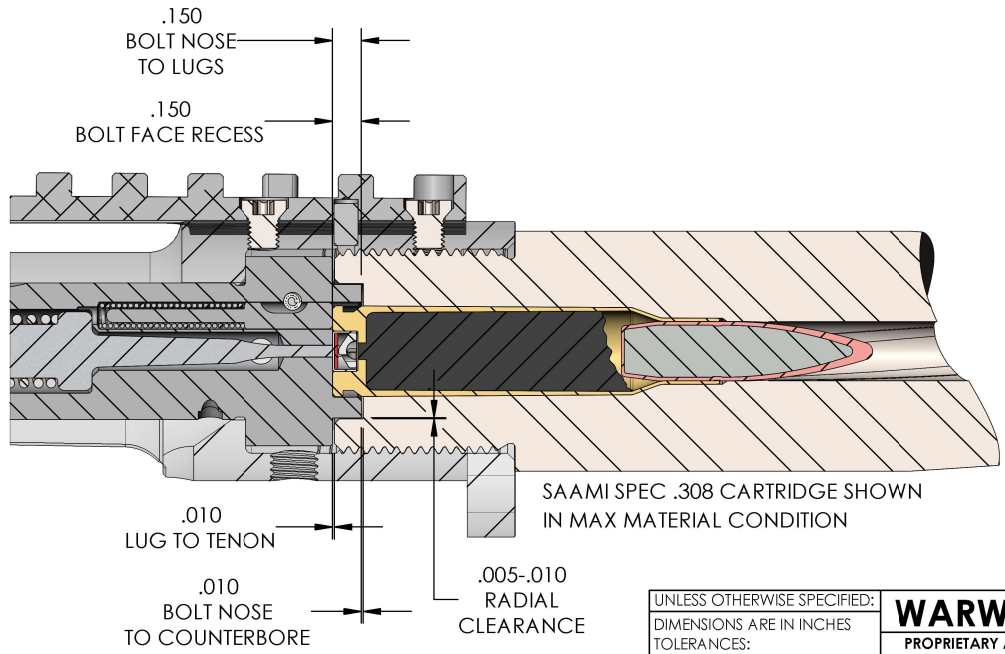

SAAMI SPEC .308 CARTRIDGE SHOWN IN MAX MATERIAL CONDITION

B

B

A

A

UNLESS OTHERWISE SPECIFIED: DIMENSIONS ARE IN INCHES TOLERANCES: FRACTIONAL $\pm 1/16$ ANGULAR: MACH $\pm .5^\circ$ TWO PLACE DECIMAL $\pm .010$ THREE PLACE DECIMAL $\pm .005$ FOUR PLACE DECIMAL $\pm .0005$		WARWICK MACHINE AND TOOL CO. INC PROPRIETARY AND CONFIDENTIAL THE INFORMATION CONTAINED IN THIS DRAWING IS THE SOLE PROPERTY OF WARWICK MACHINE AND TOOL. ANY REPRODUCTION IN PART OR AS A WHOLE WITHOUT THE WRITTEN PERMISSION OF WARWICK MACHINE AND TOOL IS PROHIBITED.			WTL 715 TENON DETAILS .950" HEADSPACE	
MATERIAL:	HEAT TREAT:	SIZE	DWG. NO.	REV		
FINISH:	DRAWN	A	GPG	D		
DO NOT SCALE DRAWING		NAME	DATE	SCALE: 1:1	SHEET 1 OF 1	
			10/03/23			

4

3

2

1